

# POWER SUPPLY KITS



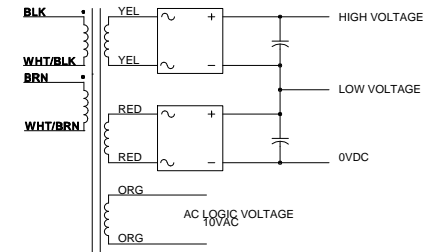
ANAHEIM AUTOMATION  
910 E. ORANGEFAIR LANE  
ANAHEIM, CA 92801

(714) 992-6990 FAX (714) 992-0471  
www.anaheimautomation.com  
e-mail: sales@anaheimautomation.com

July 8, 2002

The Bilevel Power Supply Kits in this booklet are designed to be used with Anaheim Automation Bilevel Step Motor Drivers. These Power Supply Kits supply drivers with a High Voltage, a Low Voltage, and a logic voltage. The following items should be included with the power supply kit:

- (1) Transformer
- (2) Filter Capacitors \*
- (2) Capacitor Clamps
- (2) Diode Bridges
- Misc. Hardware



\*See figures for values.

A typical hookup diagrams for the Power Supply Kits is shown above (specific hookup diagrams are shown on the inside pages). The Yellow winding is the High Voltage Winding. The Red winding is the Low voltage Winding, and the Orange winding is the Logic winding. Notice that the High Voltage is "stacked" on top of the Low Voltage supply (the "-" terminal of the High Voltage diode bridge is connected to the "+" terminal of the Low Voltage diode bridge). It is strongly recommended to "stack" the power supplies as shown in the diagrams.

Some transformers have two windings on the primary side; these transformers can be wired to operate on 115VAC nominal or 230VAC nominal. The two windings should be wired in parallel for 115VAC operation. For 230VAC operation, the two windings should be wired in series (see specific examples).

Some drivers such as the BLHP101 will also require an AC Logic voltage (orange pair winding); some drivers do not require the logic voltage (refer to the driver specifications). If your driver does not require this logic voltage, a +5VDC power supply can be created from this winding to power up other circuitry (refer to figure 6). If this winding is not used, insulate the ends of these wires with heat shrink tubing or electrical tape.

The voltages for all power supply kits are shown in the hookup diagrams. These voltages shown are the NO LOAD voltages; they will drop when the driver and motor are connected.

Below is a list of power supply kits which are compatible with the drivers listed.

DRIVER	COMPATIBLE POWER SUPPLY KITS
MBL536	PSK32791Ni
MBL600	PSK32791Ni
BLHP101	PSK42409Ni

i STANDARD KITS

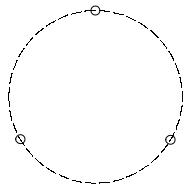
DIMENSIONS

A drawing of the transformer should be included with the power supply kit. Dimensions of the capacitors are shown in the table below.

CAPACITOR	DIAMETER	LENGTH
10,000uF 75V	2.5"	4.125"
58,000uF 16V	1.375"	3.125"
8,200uF 160V	2.0"	5.125"

The mounting hole patterns for the capacitor clamps are shown below.

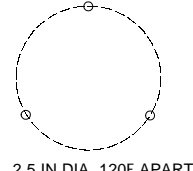
0.156 HOLE, 3 PLACES



3 IN DIA, 120E APART

10,000uF 75V

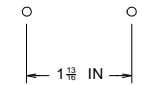
0.156 HOLE, 3 PLACES



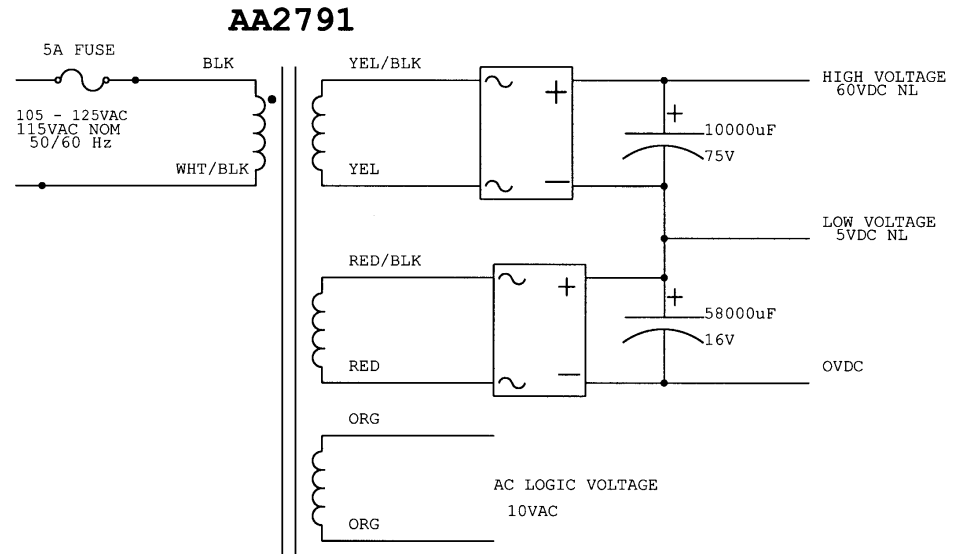
2.5 IN DIA, 120E APART

8,200uF 160V

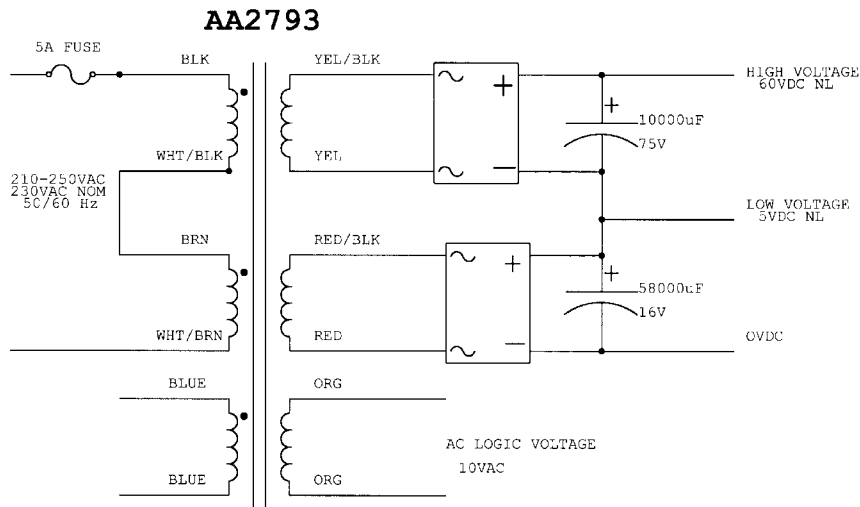
.156 HOLE, 2 PLCS



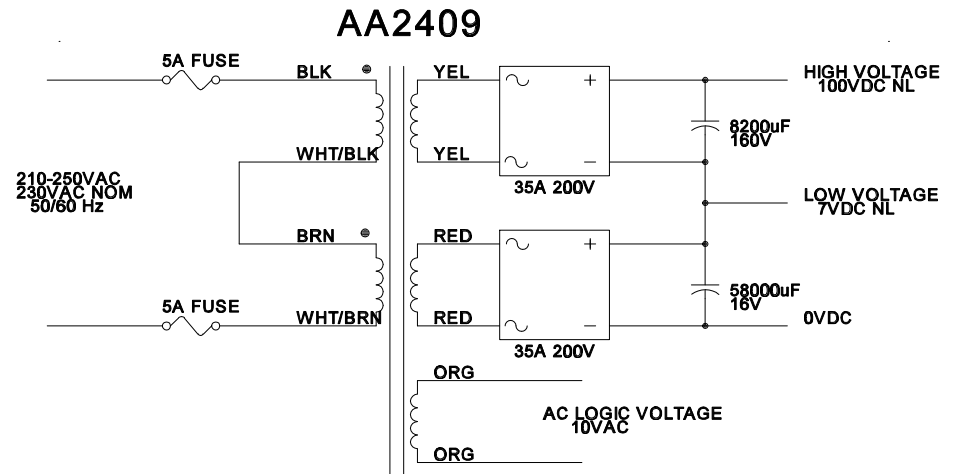
58,000uF 16V



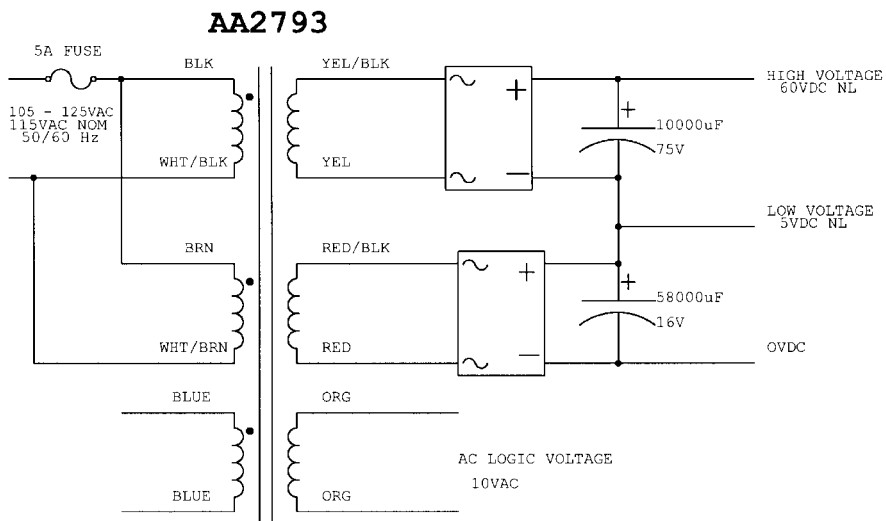
**FIGURE 1: Hookup Diagram for PSK32791N  
115VAC LINE VOLTAGE**



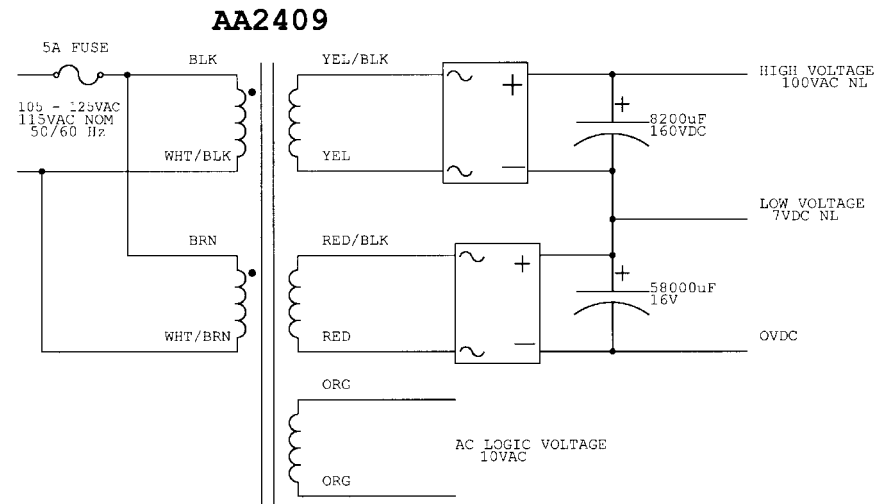
**figure2: Hookup Diagram for PSK32793N w/ 230VAC line voltage**



**FIGURE 4: Hookup Diagram for PSK42409N w/ 230VAC LINE VOLTAGE**

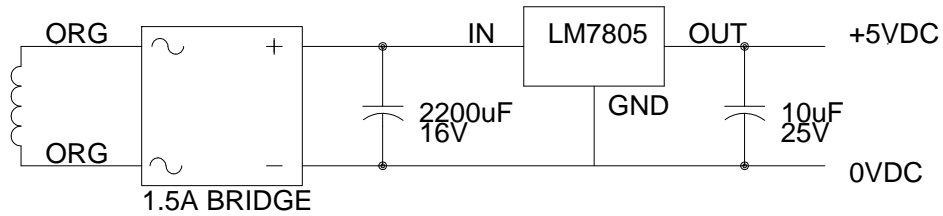


**figure3: Hookup Diagram for PSK32793N**



**115VAC LINE VOLTAGE**

**figure5: Hookup Diagram for PSK42409N**



**FIGURE 6: +5VDC @ 1 Amp Supply created from Orange Logic Windings.**

**115 VAC LINE VOLTAGE**

**910 E.ORANGFAIR LANE ANAHEIM, CA 92801  
(714) 992-6990 FAX: (714) 992-0471**

**A N A H E I M A U T O M A T I O N**